

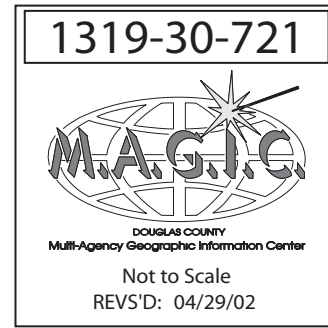

Map Legend		
	Building Footprint	001 Parcel Number
	Condo Unit	Unit 1 Parcel Lot Number



**CONDO DETAIL**

NOTE: This map is prepared for the use of Douglas County Assessor, for assessment and illustrative purposes only. It does not represent survey of the premises. No liability is assumed as to the sufficiency or accuracy of the data delineated hereon.

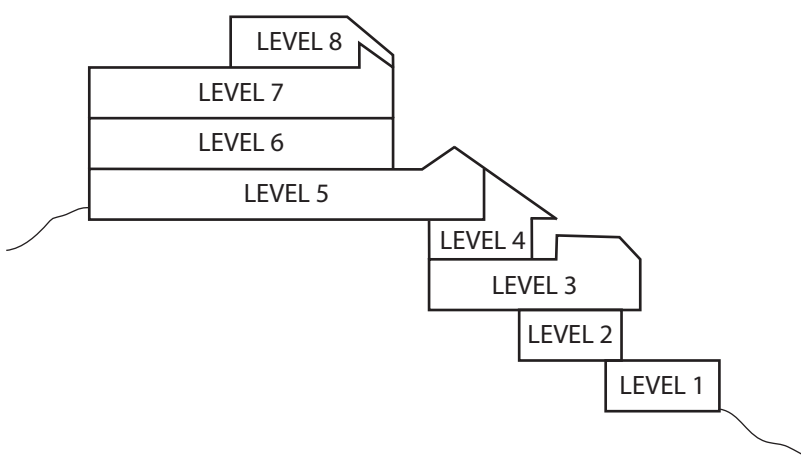
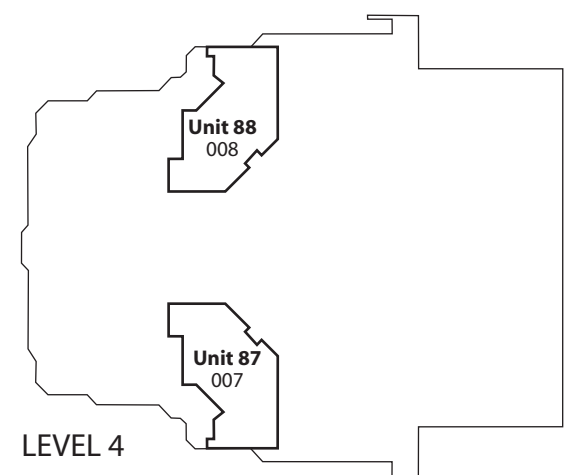
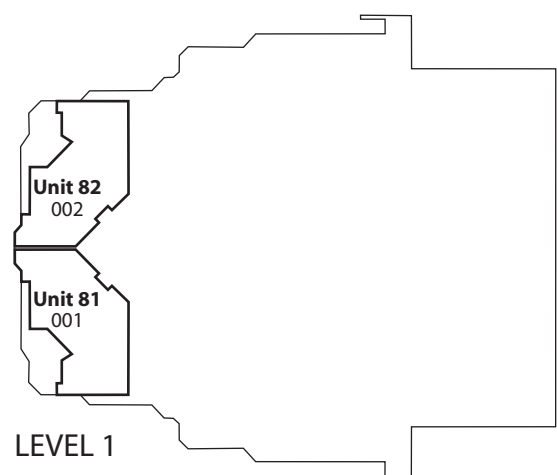
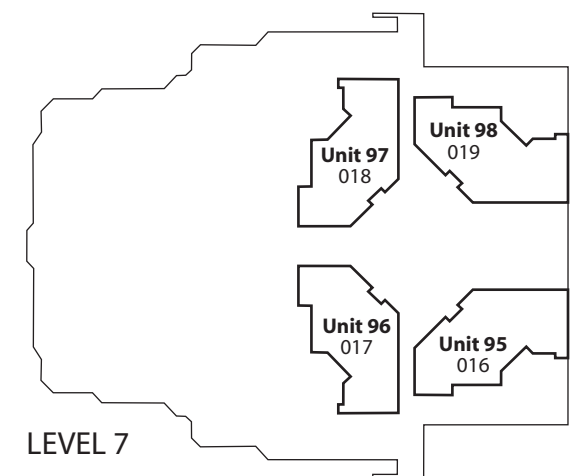
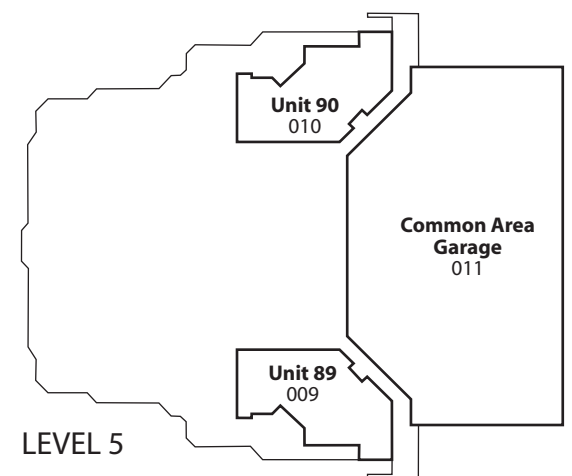
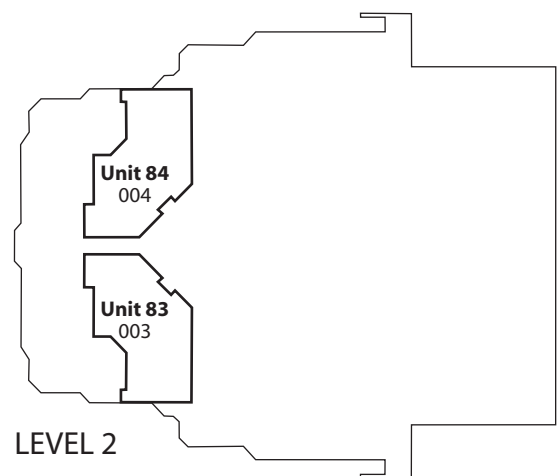
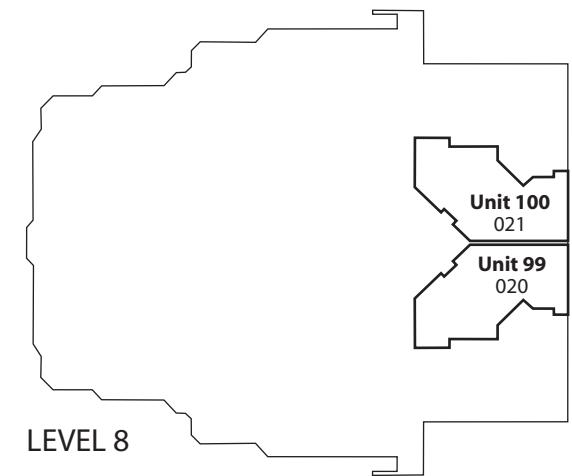
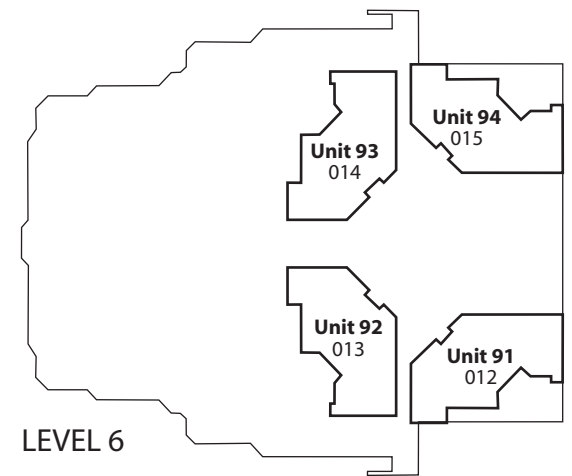
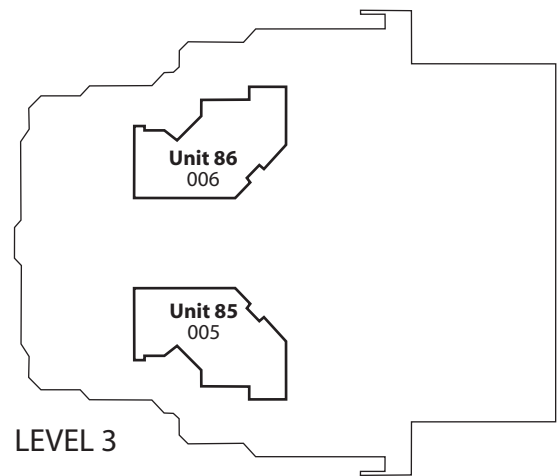

The Tahoe Ridge  
Lot 31  
Tahoe Village  
Unit 3  
420 RIDGE CLUB DR  
  
For Condo Dimensions  
Refer to Record Map  
Book 1081, Page 1653-Doc.61612